

1-Ph Sine output
up to 430/500 VA

Battery- Inverter
for Batterys 24/36/72/110V DC



- For applications on rolling stock
- Electrical safety acc. EN60950
VDE 0805, CE acc. EN50121-3-2
- Short circuit proof (dynamic / continuous)
- Synthetic sinus wave output
- Disortion factor <1,5%
- Stable regulation for any kind of loads
(capacitive, inductive, complex)
- Processor controlled / regulated
- High frequent isolation
- Efficiency up to >92%

for Railway and Special technology



© registered trademark of company SYKO GmbH & Co. KG

Series WER.H1

Main points:

Input:

- 24/36/72/110 Battery
- EMC / Disturbances EN50121-3-2
- Defined turn-on point with amplitude-time hysteresis
- Integral power run-up
- No-load power approx. 17W
- Power-Sleep mode <2mA (Σ -Inhibit) floating / polarity independent / surge proof 10 - 154V / 2mA = ON (open=OFF)
- AC-OFF: 10-90V/2mA (open=ON), surge proof
- Fuse external (customer sided)
- low 100Hz current ripple to the input side
- Connection: Wago-spring clamp 16mm²

Outputs:

- 1Ph/2Ph-sinus-voltage
- EMC / Disturbances EN50121-3-2
- Tolerance $\pm 2\% = f(U_i/I_o/T_a)$
- $U_o - 7\%$ at $U_i < 0,7 \times U_{nom}$ ¹⁾
- Dynamic over load 5s / re-start 45s³⁾
- Monitoring of rms-current
- I²t-load protection of dynamical over load³⁾
- Response time $\Delta I = 50\% < 2$ ms
- Disortion factor <1,5% (Ω -load)
- No-load and short circuit proof
- U or f/U run-up characteristic (standard: U run-up)
- Connections:
Power: Wago-spring clamp 4mm²
communication: Phoenix MSTB 2,5/6 STF-5,08
 Σ -Inhibit/Fan-Error: Phoenix MC 1,5/4-STF-3,81

General:

- Error signalling (communication)
- Status display LED (7 pc.)
- Speed/temperature controlled fans
- Test button for fan operation
- Over temperature switch-off³⁾
- 3) Locked turn-off after 5 x autostart-tries (in 60s)
New run-up only with Σ -Inhibit or U_i -off/on
- Isolation test voltage:
Input - Output: 2,5 kV_{AC} 1 min
Input - Ground: 1,5 kV_{AC} 1 min
Output - Ground: a) N on Ground 1Ph-System
optional: b) floating 2Ph-System
- Ambient temperature T_a : -25/+70°C
Option: -40/+70°C
- Derating >65°C / 2%/°C
- MTBF on request
- CE-conformation acc. EN50121-3-2
- Shock/Vibration acc. EN61373, Kat. 1, class B
50m/s²-30ms / 7,9m/s²_{rms} all directions
- Weight: approx. 5 kg
- Dimension: (348 x 263 x 125)mm
- Ground connection: M5 thread bolt

Input	Output	Power	Model number
U_i	U_o	PA stat./dyn.	
V DC	V DC	VA	
18 - 32 16,8 - 34 dyn. ¹⁾	24 230V / 50Hz	350/430	WER.H1.24.230.035/043
25 - 47 21,6 - 51 dyn. ¹⁾	36 230V / 50Hz	430/500	WER.H1.36.230.043/050
50 - 94 43 - 101 dyn. ¹⁾	72 230V / 50Hz	430/500	WER.H1.72.230.043/050
77 - 143 66 - 154 dyn. ¹⁾	110 230V / 50Hz	430/500	WER.H1.10.230.043/050

1) U_o drops to 0,93 x 230V AC by reaching the dyn. minimum input voltage

Mechanical adaptation: on request

Single projecting costs: on request

Modifikation cost for possible changes above parameters: on request

Output frequency 60Hz / 400Hz / 115Vrms: on request

* on request

Efficiency curve WER.H1

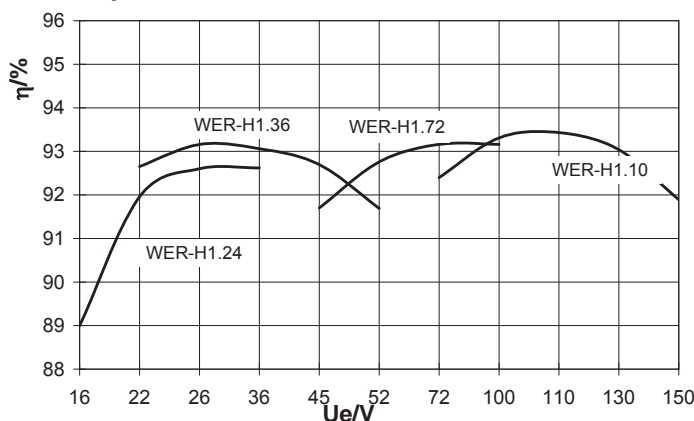

1ph/2ph inverters operate in battery networks in vehicles to supply kitchen equipment, pumps, fans, tools, passenger sockets or similar applications. The new **WER.H1** series generates a synthetic, regulated and short circuit proof 230V sinus output with an output power up to 430VA continuous and 500VA dynamic.

This inverter solution for mobile applications is designed in a modular style (DC/DC plus DC/AC-step) with high frequent protective isolation. The inverter family is defined by the use of latest power components, wide input voltage range, over voltage and transient protection, high efficiency and smart mechanical design etc. High frequent chopping currents are only processed by ceramic capacitors and foil capacitors. Low frequent currents and re-feeding is realised with high quality electrolytic capacitors. This unproblematic and flexible operating power component is characterised by the main points: input and output sided EMC-filters, monitoring and signalling functions, crystal stable output frequency, low distortion factor, voltage regulated output, dynamic and continuous short circuit protection, allowed ambient temperature up to 55°C without fan operation and up to 65°C without derating.

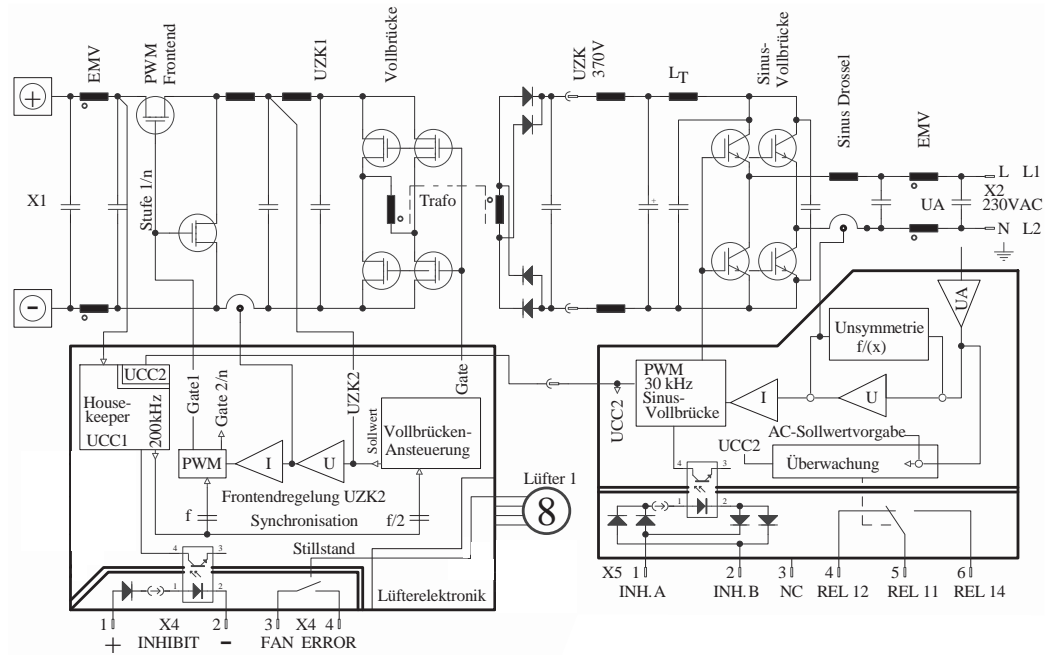

© registered trademark of company SYKO GmbH & Co. KG

following **Mechanic**

