

3Ph Sine output
bis 1800VA / 2100VA dyn.

Battery- Inverter
for Batterys 24/36/72/110V DC



- For applications on rolling stock
- Electrical safety acc. EN60950
VDE 0805, EN50121-3-2, EN61373
- Short circuit proof (dynamic / continuous)
- Synthetic sine wave output
- f/U-Control / external set point
- Processor controlled / regulated
- High frequent isolation
- Efficiency up to >92%

for railway, special technology, utility vehicles



© registered trademark of company SYKO GmbH & Co. KG

Series DRR.H4

(preliminary)

Main points:

Input:

- 24/36/72/110V Battery
- EMC / Disturbances EN50121-3-2
- Defined turn-on point with amplitude-time hysteresis
- Integral power run-up
- No-load power approx. 20W
- Power-Sleep mode <2mA (Σ -Inhibit) (X4) floating / polarity independent / surge proof 10 - 154V / 2mA = ON (open=OFF)
- Fuse external (customer sided)
- low 300Hz current ripple to the input side
- Signal inputs after arrangement (X22/23/24) 3 x Phoenix MSTB 2,5/2 STF-5,08
 - AC-OFF: 10 - 90V / 2mA (open=ON), surge proof
 - Rotation direction change
 - Failure confirmation
 - others on request
- Connection X0/X1: Würth screw terminal M8

Outputs:

- Auxiliary voltage 24V / 0,4A floating, regulated, short circuit proof, for external loads²⁾
- Synthetic 3Ph-sinus-voltage
- EMC / Disturbances EN50121-3-2
- Tolerance $\pm 5\% = f(U_i/I_o/T_a)$
- $U_o - 7\%$ at $U_i < 0,7 \times U_{nom}$ ¹⁾
- Dynamic over load 5s / re-start 45s³⁾
- I²t-load protection of dynamical over load³⁾
- No-load and short circuit proof
- f/U run-up characteristic
- f/U floating set pint input
- Connections:
 - Power: Wago-spring clamp 4mm² (X21)
 - Auxiliary: Phoenix MC 1,5/2-STF-3,81 (X3)
 - communication: 2xPhoenix MSTB 2,5/3 STF-5,08 (X25/26)
 - Σ -Inhibit/Fan-Error: Phoenix MC 1,5/4-STF-3,81 (X4)

General:

- Error signalling (communication)
- Status display LED (Blinking failure code, UCC, UI)
- Speed/temperature controlled fans >55°C
- Test button for fan operation
- Over temperature switch-off³⁾
- 3) Locked turn-off after 5 x autostart-tries (in 60s) New run-up only with Inhibit or Ui-off/on
- Isolation test voltage:
 - Input - Output: 2,5 kV_{AC} 1 min
 - Input - Ground: 1,5 kV_{AC} 1 min
 - output - Ground: 1,5 kV_{AC} 1 min
- Ambient temperature Ta: -25/+70°C
Option: -40/+70°C
- Derating >65°C / 2%/°C
- MTBF on request
- CE-conformation acc. EN50121-3-2
- Shock/Vibration acc. EN61373, Kat. 1, class B 50m/s²-30ms / 7,9m/s²_{rms} all directions
- weight: approx. 18 kg
- Dimension: (348 x 345 x 170)mm
- Ground connection: M5 thread bolt

Input	Output	Power	Model number
<u>U_i range</u>	<u>U_i nom</u>	<u>U_o rms</u>	<u>P_o cont./dyn.</u>
V DC	V DC	V AC	VA
18 - 32 16,8 - 34 dyn.	24	400 / 3Ph	1400/1700 DRR.H4.24.400.140/170
25 - 47 21,6 - 51 dyn.	36	400 / 3Phz	1700/2050 DRR.H4.36.400.170/205
50 - 94 43 - 101 dyn.	72	400 / 3Ph	1700/2050 DRR.H4.72.400.170/205
77 - 143 66 - 154 dyn.	110	400 / 3Ph	1800/2100 DRR.H4.10.400.180/210
154 - 286 132 - 308 dyn.	220	400 / 3Ph	1800/2100 on request

1) U_o drops to 0,93 x 400V AC by reaching the dyn. minimum input voltage

Mechanical adaptation: on request

Single projecting costs: on request

Modifikation cost for possible changes above parameters: on request

Output 3Ph-200Veff / 60Hz or 3Ph-115Veff / 400 Hz: on request

* on request

Efficiency curve DRR.H4

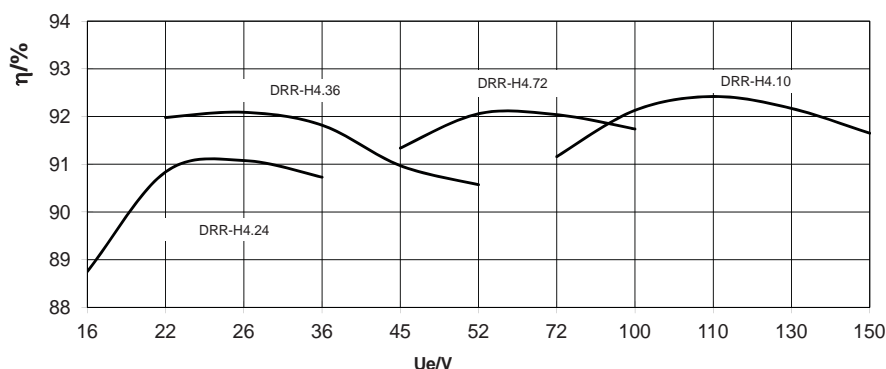

Stand: 12/15

3Ph Sine output
bis 1800VA / 2100VA dyn.

Battery- Inverter
for Batterys 24/36/72/110V DC



3ph inverters of the **DRR.H4** series operate on battery networks in vehicles to supply kitchen equipment, pumps, fans, tools, emergency ventilation or similar applications. The inverter series generates a synthetic, regulated and short circuit proof 400V 3ph-sinus output with an output power up to 3100VA dynamic. Motors can run-up to the nominal speed by f/U-regulation with the given f/U-control-function based on an internal set point curve or an external set point (DC 0-5V / PWM >5V, 0-100%).

This inverter solution for mobile applications is designed in a modular style (DC/DC plus DC/AC-step) with high frequent protective isolation. The inverter family is defined by the use of latest power components, wide input voltage range, over voltage and transient protection, high efficiency and smart mechanical design etc. High frequent chopping currents are only processed by ceramic capacitors and foil capacitors. Low frequent currents and re-feeding is realised with high quality electrolytic capacitors. This unproblematic and flexible operating power component is characterised by the following main points: input and output sided EMC-filters, monitoring and signalling functions, crystal stable output frequency, low distortion factor, voltage regulated output, dynamic and continuous short circuit protection, allowed ambient temperature up to 55°C without fan operation and up to 65°C without derating.

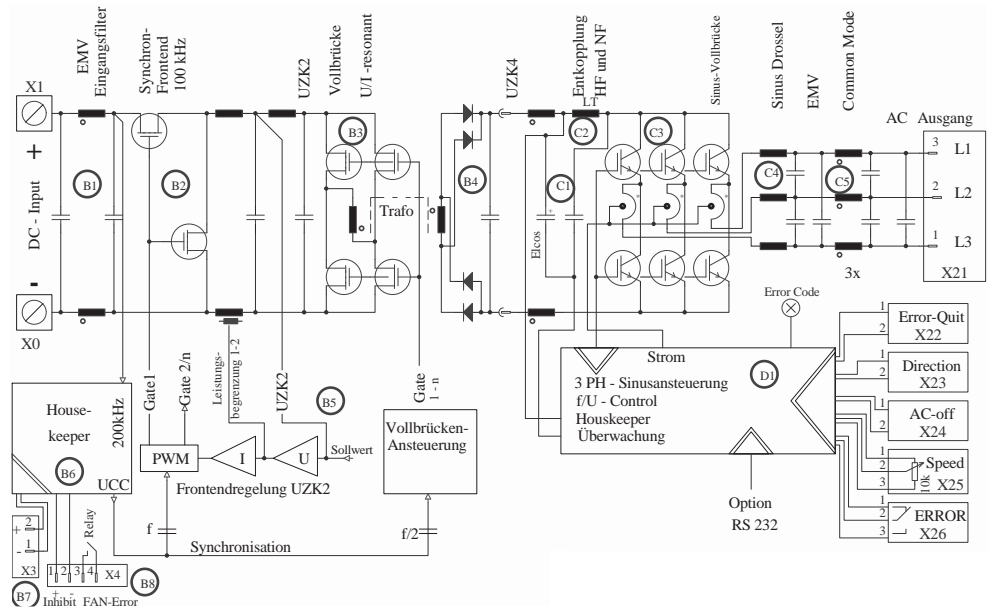

© registered trademark of company SYKO GmbH & Co. KG

Any mounting direction acc. EN61373.
Thermal mounting direction see below

